

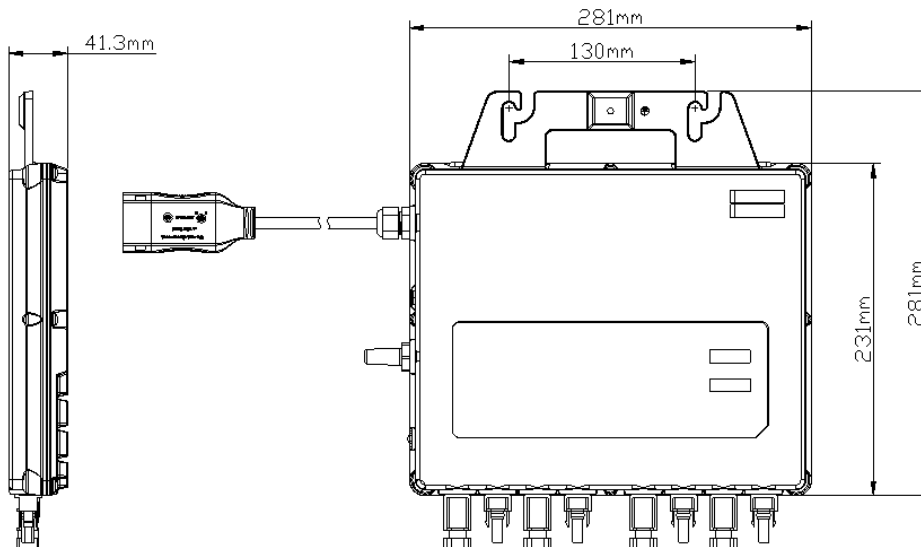

QS1 Microinverter

- Single unit connects up to four solar modules
- 4 input channels with independent MPPT and monitoring function
- Maximum output peak power of 1400 VA
- Auto disconnection device integrated

DIMENSIONS



The APsystems QS1 is a grid-tied microinverter with intelligent networking and advanced monitoring systems to ensure maximum efficiency. High efficiency, high reliability of the QS1 with 4 independent MPPT inputs, Maximum AC output power reaching 1400W. Quarter the inverters and quarter the installation means real cost savings for residential and commercial customers.

The QS1 and YC600 microinverters benefit from the same AC cables and accessories allowing, while associating them, a great flexibility on the same installation.

Datasheet | QS1 Microinverter

Region EMEA

Model QS1

Input Data (DC)

Recommended PV Module Power (STC) Range	250Wp-525Wp+
MPPT Voltage Range	22V-48V
Operation Voltage Range	16V-55V
Maximum Input Voltage	60V
Startup Voltage	20V
Maximum Input Current	12A x 4

Output Data (AC)

Maximum Continuous Output Power	1200VA
Peak Output Power	1400VA
Nominal Output Voltage/Range	230V/184-253V
Adjustable Output Voltage Range	160V-278V
Nominal Output Current	5.22A
Maximum Units per Branch	3
Nominal Output Frequency/Range	50Hz/48-51Hz
Adjustable Output Frequency Range	45.1Hz-54.9Hz
Power Factor (Adjustable)	0.8 leading...0.8 lagging
TDHI	<3%

Efficiency

Peak Efficiency	96.5%
Nominal MPPT Efficiency	99.5%
Night Power Consumption	30mW

Mechanical Data

Operating Ambient Temperature Range	-40 °C to +65 °C
Storage Temperature Range	-40 °C to +85 °C
Dimensions (W x H x D)	281mm x 231mm x 41.3mm
Weight	4.5kg
AC BUS Maximum Current	20A
Enclosure Environmental Rating	Outdoor - IP67
Connector Type	MC4 Type
Cooling	Natural Convection - No Fans

Features

Communication	ZigBee
Transformer Design	High Frequency Transformers, Galvanically Isolated
Monitoring	Via EMA* Online Portal
Warranty**	10 Years Standard ; 20 Years Optional

Certificate & Compliance

Safety and EMC Compliance	EN 62109-1;EN 62109-2;EN 61000-6-1;EN 61000-6-2; EN 61000-6-3;EN 61000-6-4
Grid Connection Compliance	VDE4105, EN50549-1, VDE0126-1-1/A1 VFR2019, UTE C15-712, ERDF-NOI-RES_13E

*Energy Management Analysis

**To be eligible for the warranty, APsystems microinverters need to be monitored via the EMA portal. Please refer to our warranty T&Cs available on emea.APsystems.com



© All Rights Reserved

Specifications subject to change without notice please ensure you are using the most recent update found at web : emea.APsystems.com

European offices

APsystems

Cypresbaan 7, 2908LT, Capelle aan den IJssel, The Netherlands

Tel : 031-10-2582670

Email : emea@apsystems.com

APsystems

Rue des Monts d'Or, ZAC de Follieuses Sud-Les Echets,

01700 Miribel, France

Email : emea@apsystems.com | Tel: +33-4-81 65 60 40

